

2000
 L-5 7G M
 3-3/4" .D.H. 1,150
 10.5G M.B
 F.V.
 Y.Y.
 Y.Y.

Y.Y.
 Y.Y.

D.Y.
 D.Y. B.Y.
 I.A. B.Y.
 D.Y.
 Y.A. C.Y.
 Y.A. C.Y.

C.Y. G.Y.
 Y.Y.

STA-RITE® HS Series Stainless Steel

2000 5 7

4" t



STA-RITE® HS Series Stainless Steel

2000 5 7

4" t

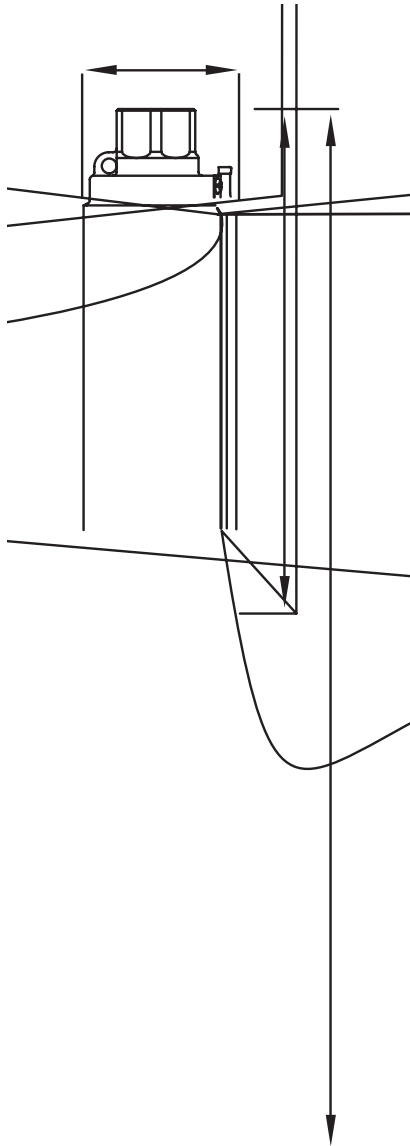

STA-RITE® HS Series Stainless Steel

2000 5 7

4" t

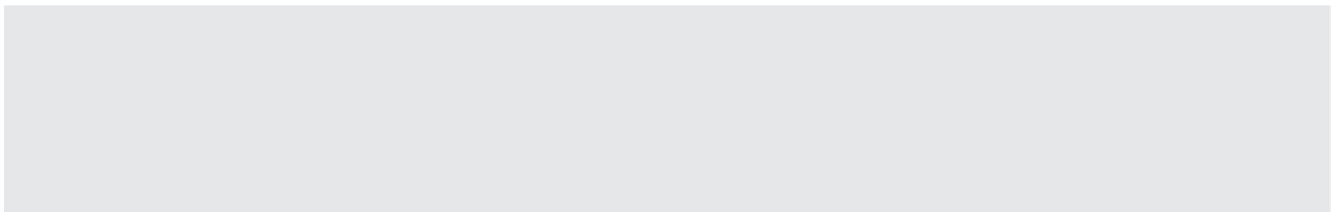
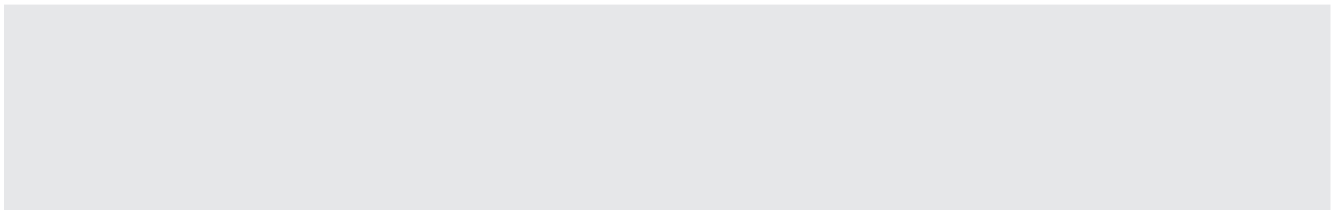
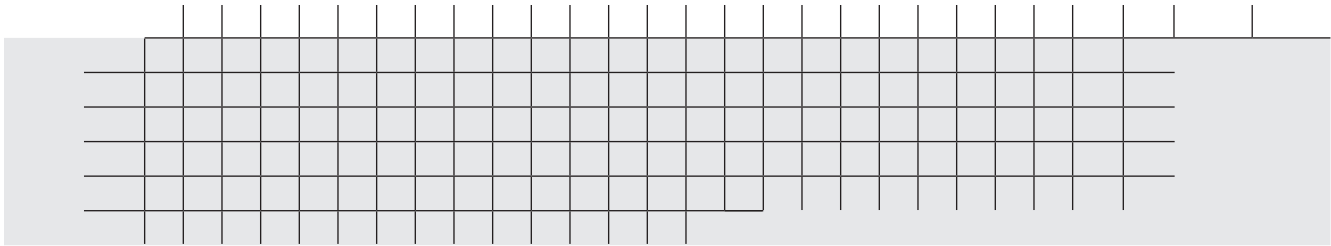

STA-RITE® HS Series Stainless Steel is a high strength, low alloy steel that is designed for use in applications where high strength and corrosion resistance are required. The HS Series is available in a variety of grades, including 304, 316, and 321. The HS Series is also available in a variety of thicknesses, including 1/8", 1/4", 3/8", 1/2", 3/4", 1", 1 1/2", 2", 3", 4", and 6". The HS Series is a popular choice for applications in the chemical, pharmaceutical, and food processing industries. For more information on the HS Series, please contact your local STA-RITE distributor.

STA-RITE® HS Series Stainless Steel

2000 5 7

4" t

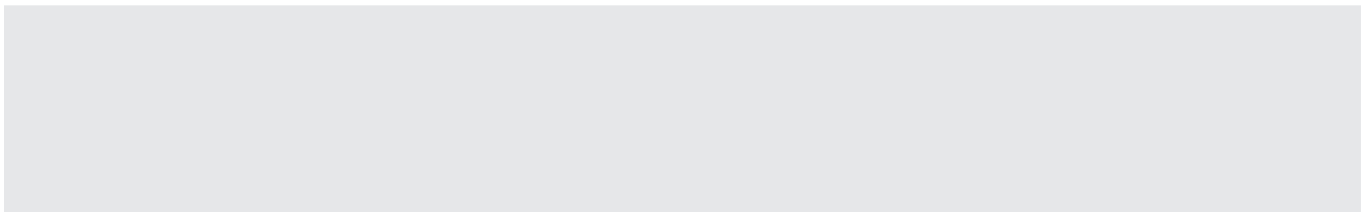
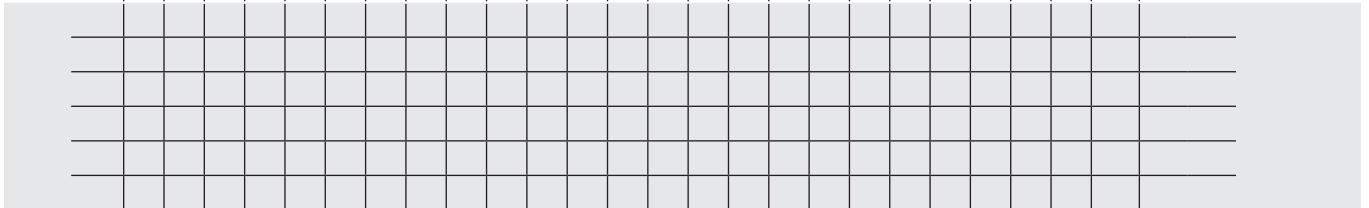
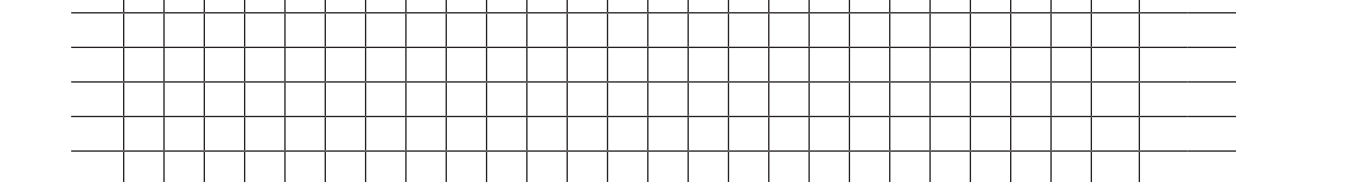
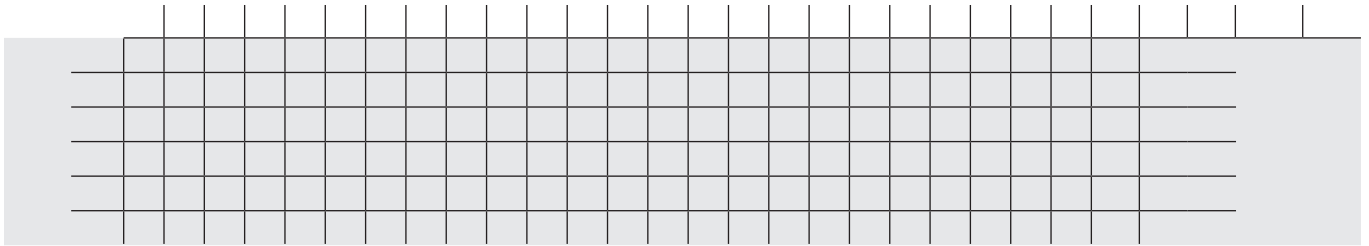

STA-RITE® HS Series Stainless Steel
2000 5 7
4" t

STA-RITE® HS Series Stainless Steel

2000 5 7

4" t

STA-RITE® HS Series Stainless Steel

2000 5 7

4" t



293 WRIGHT STREET, DELAVAN, WI 53115 WWW.STA-RITE.COM PH: 888-782-7483 ORDERS FAX: 800-426-9446
Because we are continuously improving our products and services, Pentair reserves the right to change specifications without prior notice.

