



AUROR 1

NOTE! To the installer: Please make sure you provide this manual to the owner of the equipment or to the responsible party who maintains the system.

NOTE

This repair manual is applicable to pump Models 341A, 342A and 344A. All photos illustrate Model 344A.

ATTENTION: SAFETY WARNINGS:

Read and understand all warnings before installation or servicing pump.

OPERATIONAL LIMITS: *

Maximum Operating Pressure: 175 psi at Temperatures to 150°F (65.6°C)
Maximum Operating Temperature: 225°F (107°C)

* See ASTM A126/ANSI B16.1 for pressure/temperature ratings of flanges.

ELECTRICAL SAFETY:



Warning: Electrical Shock Hazard

All electrical connections are to be made by a qualified electrician in accordance with all codes and ordinances. Failure to follow these instructions could result in serious personal

HIGH TEMPERATURE SAFETY:

HIGH PRESSURE SAFETY:

SERVICE

Your Aurora pump requires no maintenance other than periodic inspection, occasional cleaning and lubrication of bearings (MODEL 344A only). The intent of inspection is to prevent breakdown, thus obtaining optimum service life. The liquid end of the pump is lubricated by the fluid being pumped and therefore does not require periodic lubrication. The motor, however may require lubrication, in which case, the motor manufacturer's recommendation should be followed.

LUBRICATION OF IMPELLER SHAFT BEARINGS

The MODEL 344A pump is available with three options for lubricating the shaft bearings. They are:

1. Regreasable (standard)
2. Oil Lubrication
3. Sealed Bearings, Permanent Lubrication

Regreasable bearings will require periodic lubrication and can be accomplished by using the zerk or lubrication fittings in the cartridge cap and power frame. Lubricate the bearings at regular intervals using a grease of high quality. Polyurea base grease is recommended as lubricants for pumps operating in both wet and dry locations. Mixing of different brands of grease should be avoided due to possible chemical reactions between the brands which could damage the bearings. Accordingly, avoid grease of vegetable or animal base which can develop acids, as well as grease containing rosin, graphite, talc and other impurities. Under no circumstances should used grease be reused.

MODELS 341A-342A-344A

Over lubrication should be avoided as it may result in overheating and possible bearing failure. Under normal application, adequate lubrication is assured if the amount of grease is maintained at 1/3 to 1/2 the capacity of the bearing and adjacent space surrounding it.

In dry locations, each bearing will need lubrication at least every 600 hours of running time or every 6 to 12 months, whichever is more frequent. In wet locations the bearings should be lubricated at least after every 300 hours of running time or every 4 to 6 months, whichever is more frequent. A unit is considered to be installed in a wet location if the pump and motor are exposed to dripping water, to the weather, or to heavy condensation such as is found in unheated and poorly ventilated underground locations.

Oil lubricated bearings are optional on MODEL 344 pumps. A fixed oil level is maintained with the power frame by an oiler which allows visual indications of reserve oil.

At initial installation and before starting a unit that has been shut down for repairs or for any extended length of time, run enough 10W-30 weight motor oil through the oiler to maintain a constant oil level to insure that the bearing will never be without an oil supply. Oil will have to be added at intervals to maintain a constant level in the oiler. This interval can only be determined by experience.

Under working conditions, oil will breakdown and need to be replaced at regular intervals. The length of these intervals will depend on many factors. Under normal operation, in clean and dry locations, the oil should be changed about once a year. However, when the pump is exposed to dirt contamination, high temperatures (200°F. or above) or a wet location, the oil may have to be changed every 2 to 3 months.

CAUTION

Use normal fire caution procedures when using any

MODELS 341A-342A-344A

DISASSEMBLY

Disassemble only what is needed to make repairs or accomplish inspection. (See Figure 2 for Model 341A, Figure 3 for Model 342A and Figure 3 for Model 344A.)

1. Disconnect and lockout power source to prevent drive unit from being energized during disassembly.
2. Unscrew the two drain plugs (4) from the casing (6). On Model 342A pumps, remove plugs (74 and 75) to drain pump. Also unscrew the two plugs (4) from casing (6).
3. Remove all relief, cooling, flushing or drain lines from pump, including compression connections (1 and 2) and tubing (3). Break suction and discharge connections unless it is intended to remove the power frame or motor assembly and leave casing (6) in the line. On Model 342A pumps,

MODELS 341A-342A-344A

13. The seal flexible cup and stationary seat should be pressed out of the bracket (35) and the cavity cleaned of all residue. Make sure that the 1/32 inch radius in the seal seat cavity is not damaged during disassembly since a sharp edge can easily cut the flexible cup during reassembly.

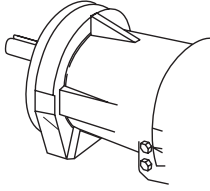

MODELS 341A-342A-344A

MODELS 341A-342A-344A

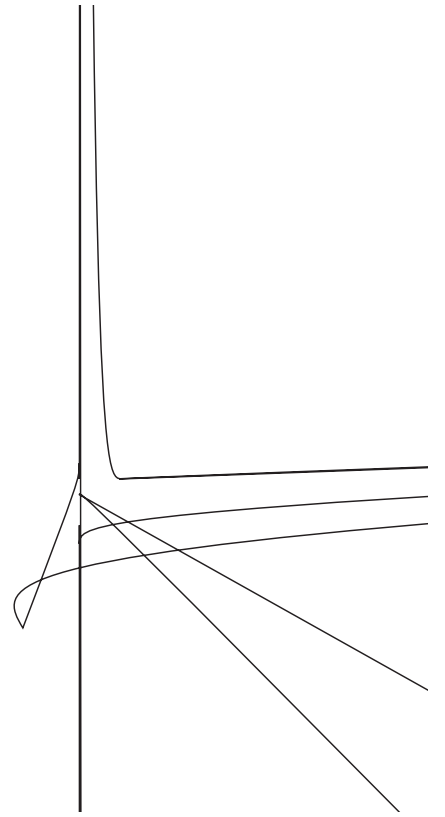
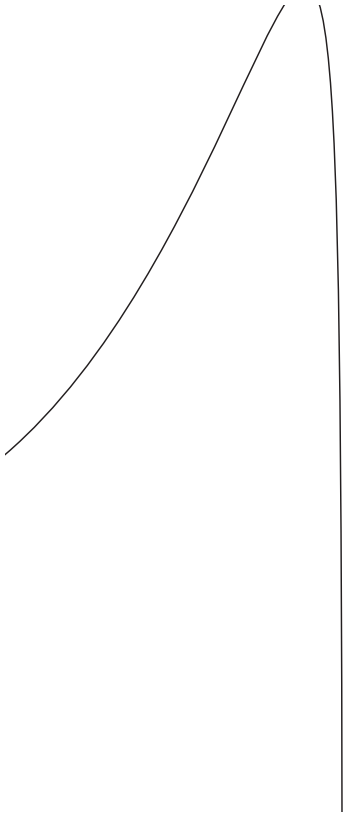

MODELS 341A-342A-344A

MODEL 341A LIST OF PARTS

- | | | |
|-------------------|-------------------|---------------|
| 1. Elbow | 9A. Washer | 27. Seal |
| 2. Connector | 9B. Gasket | 32. Capscrew |
| 3. Tubing | 9C. Capscrew Seal | 33. Screw |
| 4. Plug, Pipe | 10. Gasket | 34. Nameplate |
| 5. Capscrew | 11. Impeller | 35. Bracket |
| 6. Casing | 12. Impeller Key | 39. Capscrew |
| 7. Wear Ring | 14. Wear Ring | 40. Washer |
| 8. Gasket | 15. Wear Ring | 41. Support |
| 9. Impeller Screw | 16. Wear Ring | 61. Pin |
| | 25. Sleeve | |

MODEL 342A LIST OF PARTS

- | | | |
|-------------------|-------------------|----------------|
| 1. Elbow | 9B. Gasket | 33. Screw |
| 2. Connector | 9C. Capscrew Seal | 34. Nameplate |
| 3. Tubing | 10. Gasket | 35. Bracket |
| 4. Plug, Pipe | 11. Impeller | 39. Capscrew |
| 5. Capscrew | 12. Impeller Key | 61. Pin |
| 6. Casing | 14. Wear Ring | 72. Gasket |
| 7. Wear Ring | 15. Wear Ring | 73. Base |
| 8. Gasket | 16. Wear Ring | 74. Plug, Pipe |
| 9. Impeller Screw | 25. Sleeve | 75. Plug, Pipe |
| 9A. Washer | 27. Seal | |
| | 32. Capscrew | |

MODEL 344A LIST OF PARTS

- | | |
|-------------------|---------------|
| 1. Elbow | 27. Seal |
| 2. Connector | 32. Capscrew |
| 3. Tubing | 33. Screw |
| 4. Plug, Pipe | 34. Nameplate |
| 5. Capscrew | 35. Bracket |
| 6. Casing | 39. Capscrew |
| 7. Wear Ring | 40. Washer |
| 8. Gasket | 41. Support |
| 9. Impeller Screw | 42. Key |
| 9A. Washer | |
| 9B. Gasket | |
| 9C. Capscrew Seal | |
| 10. Gasket | |
| 11. Impeller | |
| 12. Impeller Key | |
| 14. Wear Ring | |
| 15. Wear Ring | |
| 16. Wear Ring | |

NOTES:

1. BRONZE FITTED CONSTRUCTION WILL BE FURNISHED AS STANDARD UNLESS SPECIFIED.
2. REFER TO FACTORY FOR SPECIAL ALLOYS.
3. AURORA PUMP RESERVES THE RIGHT TO SUBSTITUTE MATERIALS WITHOUT NOTICE
4. PIECE NUMBERS 14 AND 15 ARE NOT FURNISHED AS STANDARD, WHEN FURNISHED, IMPELLER MUST BE MODIFIED.
5. PIECE NUMBERS 39, 40, 41 USED ONLY WITH MOTOR FRAMES 143 THRU 184-JM ON MODEL 341A PUMPS.

NOTE

WHEN ORDERING SPARE PARTS ALWAYS INCLUDE THE PUMP TYPE, SIZE, SERIAL NUMBER, AND THE PIECE NUMBER FROM THE EXPLODED VIEW IN THIS MANUAL.

ORDER ALL PARTS FROM YOUR LOCAL AUTHORIZED DISTRIBUTOR, FACTORY BRANCH SALES OFFICE OR THE FACTORY AT NORTH AURORA, ILLINOIS.

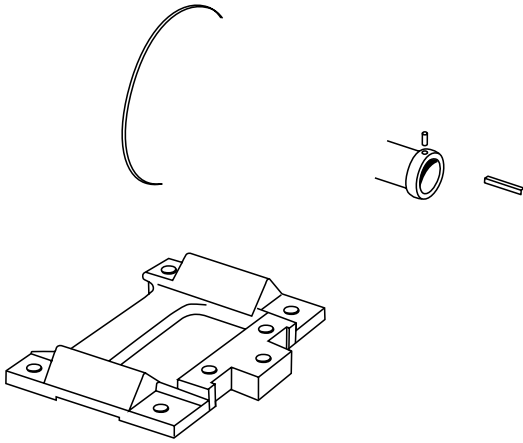

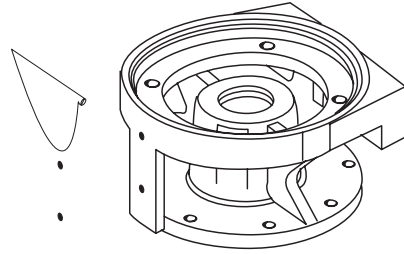

|

MODEL 344A

